

PH 0697796

UNITED STATES DEPARTMENT OF THE INTERIOR
NATIONAL PARK SERVICE

FOR NPS USE ONLY
RECEIVED FEB 22 1979
JUN 12 1980
DATE ENTERED

**NATIONAL REGISTER OF HISTORIC PLACES
INVENTORY -- NOMINATION FORM**

SEE INSTRUCTIONS IN *HOW TO COMPLETE NATIONAL REGISTER FORMS*
TYPE ALL ENTRIES -- COMPLETE APPLICABLE SECTIONS

1 NAME

HISTORIC
Brandon Hall
AND/OR COMMON
Brandon Hall

2 LOCATION

STREET & NUMBER
Brandon Hall
CITY, TOWN
Washington
STATE
Mississippi
VICINITY OF
X NE of Washington in U.S. 61
CODE
28
CONGRESSIONAL DISTRICT
Fourth
COUNTY
Adams
CODE
1

3 CLASSIFICATION

CATEGORY	OWNERSHIP	STATUS	PRESENT USE
<input type="checkbox"/> DISTRICT	<input type="checkbox"/> PUBLIC	<input checked="" type="checkbox"/> OCCUPIED	<input type="checkbox"/> AGRICULTURE
<input checked="" type="checkbox"/> BUILDING(S)	<input checked="" type="checkbox"/> PRIVATE	<input type="checkbox"/> UNOCCUPIED	<input type="checkbox"/> MUSEUM
<input type="checkbox"/> STRUCTURE	<input type="checkbox"/> BOTH	<input type="checkbox"/> WORK IN PROGRESS	<input type="checkbox"/> COMMERCIAL
<input type="checkbox"/> SITE	PUBLIC ACQUISITION	ACCESSIBLE	<input type="checkbox"/> PARK
<input type="checkbox"/> OBJECT	<input type="checkbox"/> IN PROCESS	<input checked="" type="checkbox"/> YES: RESTRICTED	<input checked="" type="checkbox"/> PRIVATE RESIDENCE
	<input type="checkbox"/> BEING CONSIDERED	<input type="checkbox"/> YES: UNRESTRICTED	<input type="checkbox"/> ENTERTAINMENT
		<input type="checkbox"/> NO	<input type="checkbox"/> RELIGIOUS
			<input type="checkbox"/> GOVERNMENT
			<input type="checkbox"/> INDUSTRIAL
			<input type="checkbox"/> TRANSPORTATION
			<input type="checkbox"/> MILITARY
			<input type="checkbox"/> OTHER:

4 OWNER OF PROPERTY

NAME
Mr. and Mrs. Raymond St. Germaine
STREET & NUMBER
Brandon Hall
CITY, TOWN
Washington
STATE
Mississippi 39190
VICINITY OF

5 LOCATION OF LEGAL DESCRIPTION

COURTHOUSE, OFFICE OF THE CHANCERY CLERK
REGISTRY OF DEEDS, ETC. Adams County Courthouse
STREET & NUMBER
Courthouse Square
CITY, TOWN
Natchez
STATE
Mississippi 39120

6 REPRESENTATION IN EXISTING SURVEYS

TITLE
Statewide Survey of Historic Sites
DATE
May 28, 1973
DEPOSITORY FOR SURVEY RECORDS
Mississippi Department of Archives and History
CITY, TOWN
Jackson
STATE
Mississippi 39205
FEDERAL STATE COUNTY LOCAL

7 DESCRIPTION

CONDITION		CHECK ONE	CHECK ONE
<input checked="" type="checkbox"/> EXCELLENT	<input type="checkbox"/> DETERIORATED	<input type="checkbox"/> UNALTERED	<input checked="" type="checkbox"/> ORIGINAL SITE
<input type="checkbox"/> GOOD	<input type="checkbox"/> RUINS	<input checked="" type="checkbox"/> ALTERED	<input type="checkbox"/> MOVED DATE _____
<input type="checkbox"/> FAIR	<input type="checkbox"/> UNEXPOSED		

DESCRIBE THE PRESENT AND ORIGINAL (IF KNOWN) PHYSICAL APPEARANCE

Located in a parklike setting east of the Natchez Trace Parkway northeast of Washington, Mississippi, Brandon Hall is a large two-story Greek Revival residence. Constructed in 1856, the house is frame above a brick foundation, and is covered by a tall pyramidal roof. A U-shaped Ionic colonnade forms a lower gallery along front and side elevations and is superimposed on the facade by a Corinthian colonnade modeled on the Temple of the Winds. A cast-iron railing with a lyre motif runs between the columns, except where gracefully flared steps descend to the ground. The facade (or north elevation) is a five-bay composition with a center entrance placed behind a handsome Ionic frontispiece with columns and antae supporting a full entablature. A similar frontispiece of the Corinthian order frames the doorway of the upper gallery, with additional access to both galleries provided by jib doors below the double-hung six-over-six windows. Where protection from inclement weather is provided by the galleries, scored stucco-on-lath is used instead of the less elegant clapboarding, which sheathes the exterior elsewhere.

The interior of Brandon Hall is arranged in a triple-pile plan with an expansive central hall (eighteen by sixty-two feet) flanked by double parlors and a dining room on the west and by three large chambers opposite. Modern bathrooms and a kitchen have been installed in the cabinets, which were created apparently in the nineteenth century by enclosing the end bays of the one-story rear gallery, the center portion of which retains its original blinds and lattice, a testament to the protection from the elements provided by the gallery. Of the several varieties of Greek Revival trim used to decorate the interior, the most elaborate scheme is reserved for the central hall and double parlors, where window and door surrounds are symmetrically molded with corner blocks, and the plaster entablatures and centerpieces host a wide variety of Grecian motifs, such as water leaf, egg-and-dart, palm, honeysuckle, and acanthus. Black marble mantels are designed with pilasters supporting uncarved friezes and shelves. Less ambitious trim is used in the dining room and library, where pilastered mantels are wood, cornices have the simple Tuscan profile, and window and door surrounds are typical battered-and-eared architraves, which rise slightly on axes to suggest pediments. Like dining rooms at many other substantial houses of the area, the dining room at Brandon Hall was equipped with a punkah, now missing, which hung from a U-shaped iron bracket anchored to the ceiling through a pair of cast-plaster centerpieces. Other less public rooms, such as the six bedrooms upstairs, have little ornamental plaster and are trimmed only with simple door and window architraves.

FHR-8-300A
(11/78)

UNITED STATES DEPARTMENT OF THE INTERIOR
HERITAGE CONSERVATION AND RECREATION SERVICE

**NATIONAL REGISTER OF HISTORIC PLACES
INVENTORY -- NOMINATION FORM**

FOR HCRS USE ONLY
RECEIVED APR 30 1980
DATE ENTERED 12

CONTINUATION SHEET

ITEM NUMBER 7 PAGE 1

Of the three outbuildings shown on the USGS map, only one survives. To the southwest of the main house is a one-story frame outbuilding with gabled roof. This building appears to be original to Brandon Hall but has been altered by later additions. To the south and slightly east is a one-story brick garage building with gabled roof. A portion of this building (the northernmost half) is possibly the original kitchen. This outbuilding does not show up on the USGS map.

8 SIGNIFICANCE

PERIOD	AREAS OF SIGNIFICANCE -- CHECK AND JUSTIFY BELOW				
<input type="checkbox"/> PREHISTORIC	<input type="checkbox"/> ARCHEOLOGY-PREHISTORIC	<input type="checkbox"/> COMMUNITY PLANNING	<input type="checkbox"/> LANDSCAPE ARCHITECTURE	<input type="checkbox"/> RELIGION	
<input type="checkbox"/> 1400-1499	<input type="checkbox"/> ARCHEOLOGY-HISTORIC	<input type="checkbox"/> CONSERVATION	<input type="checkbox"/> LAW	<input type="checkbox"/> SCIENCE	
<input type="checkbox"/> 1500-1599	<input type="checkbox"/> AGRICULTURE	<input type="checkbox"/> ECONOMICS	<input type="checkbox"/> LITERATURE	<input type="checkbox"/> SCULPTURE	
<input type="checkbox"/> 1600-1699	<input checked="" type="checkbox"/> ARCHITECTURE	<input type="checkbox"/> EDUCATION	<input type="checkbox"/> MILITARY	<input type="checkbox"/> SOCIAL/HUMANITARIAN	
<input type="checkbox"/> 1700-1799	<input type="checkbox"/> ART	<input type="checkbox"/> ENGINEERING	<input type="checkbox"/> MUSIC	<input type="checkbox"/> THEATER	
<input checked="" type="checkbox"/> 1800-1899	<input type="checkbox"/> COMMERCE	<input type="checkbox"/> EXPLORATION/SETTLEMENT	<input type="checkbox"/> PHILOSOPHY	<input type="checkbox"/> TRANSPORTATION	
<input type="checkbox"/> 1900-	<input type="checkbox"/> COMMUNICATIONS	<input type="checkbox"/> INDUSTRY	<input type="checkbox"/> POLITICS/GOVERNMENT	<input type="checkbox"/> OTHER (SPECIFY)	
		<input type="checkbox"/> INVENTION			

SPECIFIC DATES 1856

BUILDER/ARCHITECT

STATEMENT OF SIGNIFICANCE

Brandon Hall is perhaps the grandest of the extant antebellum plantation houses of Adams County, Mississippi, where most mansions were built as townhouses or suburban villas for Natchez planters whose plantations were across the Mississippi River in Louisiana or upriver in the Mississippi Delta. The house gains further significance as the most outstanding frame mansion in the county and as the residence of the Brandon family, original members of the county cotton aristocracy.

Brandon Hall was built by Gerard Brandon and his wife, Charlotte Smith Brandon (Biographical and Historical Memoirs of Mississippi [Chicago: The Goodspeed Publishing Co., 1891], II, 817). Documentary (Ibid.) and stylistic evidence place the date of construction at 1856. The frame construction and vernacular use of Grecian motifs combine to make the house more typical of the mansions of neighboring Jefferson and Claiborne counties than of the brick mansions of Adams County. Gerard Brandon was the son of Gov. Gerard Chittoque Brandon, who was born in Adams County in 1788 and served as Mississippi's first native-born governor (1825-1832). The Brandons were among the leading families of Adams County, an area in which leadership changed little from 1788 to 1860. After the deaths of Gerard Brandon and his wife in the 1870s (Ibid.), the house became the residence of principally Aaron Stanton and his wife, Elizabeth, Gerard Brandon's daughter. (Aaron Stanton was the son of David Stanton, who added the ca. 1850 wing to the Elms, a National Register of Historic Places property.) The house remained in the possession of Brandon descendants until 1914, when it was lost because of a mortgage foreclosure (Adams Co., Miss., Deed Book 4E:118). In 1970, Brandon Hall was purchased by Mr. and Mrs. Raymond St. Germaine, who have restored the house.

9 MAJOR BIBLIOGRAPHICAL REFERENCES

Adams Co., Miss. Chancery Clerk. Deed Book 4E.

Allen, William C. Inspection of Brandon Hall, Adams Co., Miss., November, 1978.

Biographical and Historical Memoirs of Mississippi. 2 vols. Chicago: The Goodspeed Publishing Company, 1891.

10 GEOGRAPHICAL DATA

UTM NOT VERIFIED ACREAGE NOT VERIFIED

ACREAGE OF NOMINATED PROPERTY 40.18 acres

QUADRANGLE NAME Washington, Miss.

QUADRANGLE SCALE 1:24000

UTM REFERENCES

A 1,5 | 6,6,5,9,5,5 | 3,4,9,9,2,2,5

B 1,5 | 6,6,5,9,5,5 | 3,4,9,8,4,8,5

ZONE EASTING NORTHING

ZONE EASTING NORTHING

C 1,5 | 6,6,5,5,3,0 | 3,4,9,8,4,8,5

D 1,5 | 6,6,5,5,2,5 | 3,4,9,9,2,3,0

E | |

F | |

G | |

H | |

VERBAL BOUNDARY DESCRIPTION

Beginning at a concrete monument stamped monument No. 21 NPS on the southerly right-of-way of Natchez Trace Parkway Project 3-W, being on the northerly boundary of the herein

LIST ALL STATES AND COUNTIES FOR PROPERTIES OVERLAPPING STATE OR COUNTY BOUNDARIES

STATE	CODE	COUNTY	CODE

11 FORM PREPARED BY

NAME / TITLE William C. Allen, author of physical description
Mary Warren Miller

ORGANIZATION Private consultants

DATE December 13, 1978

STREET & NUMBER 506 High Street

TELEPHONE 601-442-9786

CITY OR TOWN Natchez

STATE Mississippi 39120

12 STATE HISTORIC PRESERVATION OFFICER CERTIFICATION

THE EVALUATED SIGNIFICANCE OF THIS PROPERTY WITHIN THE STATE IS:

NATIONAL STATE X LOCAL

As the designated State Historic Preservation Officer for the National Historic Preservation Act of 1966 (Public Law 89-665), I hereby nominate this property for inclusion in the National Register and certify that it has been evaluated according to the criteria and procedures set forth by the National Park Service.

STATE HISTORIC PRESERVATION OFFICER SIGNATURE Elmer B. Williams

TITLE State Historic Preservation Officer

DATE February 14, 1979

FOR NPS USE ONLY

I HEREBY CERTIFY THAT THIS PROPERTY IS INCLUDED IN THE NATIONAL REGISTER

W. Ray Lee
KEEPER OF THE NATIONAL REGISTER
ATTEST: Cecil Dubois
CHIEF OF REGISTRATION

DATE 6/12/80

DATE 6/8/80

FHR-8-300A
(11/78)

UNITED STATES DEPARTMENT OF THE INTERIOR
HERITAGE CONSERVATION AND RECREATION SERVICE

**NATIONAL REGISTER OF HISTORIC PLACES
INVENTORY -- NOMINATION FORM**

FOR HCRS USE ONLY
RECEIVED
DATE ENTERED

APR 30 1980

1.2

CONTINUATION SHEET

ITEM NUMBER 8 PAGE 1

Brandon Hall's approximately forty acres are important in maintaining the historical landscape of the property. The house is set in a park-like environment that stretches from the Natchez Trace Parkway to United States Highway 61. Large vistas extend from all sides of the house, and much old plant material remains.

UNITED STATES DEPARTMENT OF THE INTERIOR
NATIONAL PARK SERVICE

**NATIONAL REGISTER OF HISTORIC PLACES
INVENTORY -- NOMINATION FORM**

FOR NPS USE ONLY	FEB 22 1979
RECEIVED	
DATE ENTERED	JUN 12 1980

CONTINUATION SHEET

ITEM NUMBER 10 PAGE 1

10 - GEOGRAPHICAL DATA

described property; thence in a southwesterly direction, along the southerly right of way of Natchez Trace Parkway Project 3-W, S33° 55' W a distance of 900.0 feet to concrete monument No. 20; thence S 45° 15' W a distance of 170.0 feet to concrete monument No. 20-A, being the northwest corner of the herein described property; thence in a southeasterly direction, along an old fence line, S 49° 45' E a distance of 312.0 feet; thence S 08° 30' E a distance of 415.6 feet; thence S 02° 00' E a distance of 735.2 feet to the northerly right-of-way of U. S. Highway 61 North; thence in an easterly direction along the arc of a curve, along the northerly right-of-way of U. S. Highway 61, a distance of 261.7 feet to the end of said curve; thence in a northeasterly direction along the northerly right-of-way of U. S. Highway 61 N 66° 00' E a distance of 550.0 feet to the southeastern corner of the herein described property, said point being the southwest corner of the Lumm Property, as shown on map and plat recorded in Deed Book 5-E, pages 265 and 267, of the Deed Records of Adams County, Mississippi; thence in a northeasterly, southwesterly, and northeasterly direction along the westerly boundary of the Lumm Property, said line being the easterly boundary of the herein described property; N 35° 15' W for a distance of 170 feet; thence N 28° 15' E for a distance of 346.0 feet; thence N 12° 30' E for a distance of 372.0 feet; thence N 04° 25' E for a distance of 594.0 feet; thence S 75° 30' W for a distance of 275.0 feet; thence N 06° 45' W for a distance of 529.0 feet; thence N 38° 30' W for a distance of 376.0 feet; to the right-of-way of Natchez Trace Parkway Project 3W, said point being the northeast corner of the herein described property; thence in a southwesterly direction, along the southerly right-of-way of that Natchez Trace Parkway Project 3-W S 24° 55' W for a distance of 220.0 feet to the point of beginning, containing 40.18 acres.

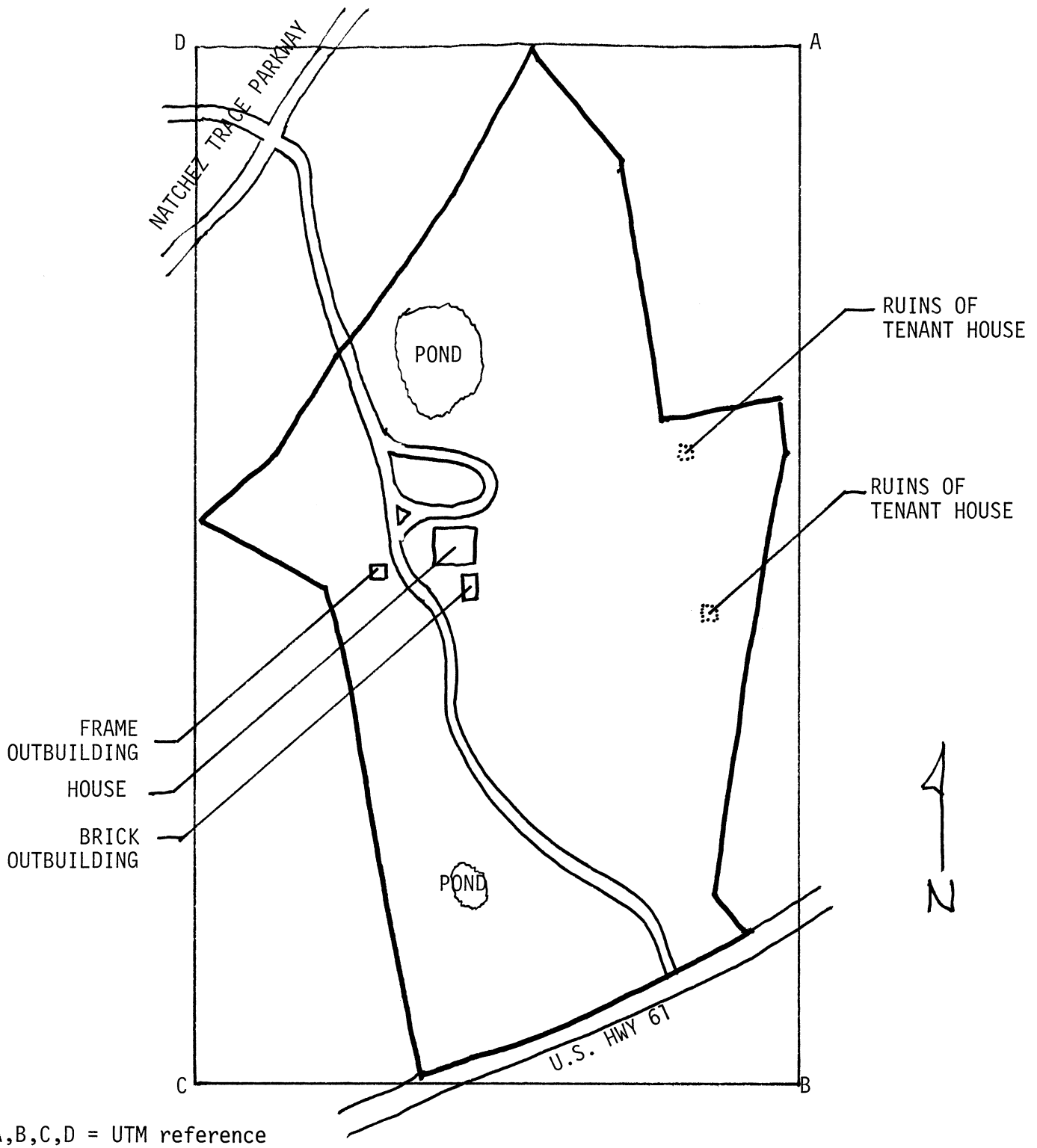

A,B,C,D = UTM reference

S K E T C H M A P

Brandon Hall
vic. Washington, Adams Co., Mississippi

APR 30 1980



BRANDON HALL

Washington, Adams County, Mississippi

From the northwest, the front (north)
elevation.

Photo 1 of 5

FEB 22 1979

JUN 12 1980



BRANDON HALL

Washington, Adams County, Mississippi

From the southwest, the rear (south) elevation.

Photo 2 of 5

FEB 22 1979

JUN 12 1980



BRANDON HALL

Washington, Adams County, Mississippi

From the north, the central hall.

Photo 3 of 5

FEB 22 1979

JUN 12 1980



BRANDON HALL

Adams County, Mississippi

JUN 1 2 1980

Mary W. Miller--1979

From the northeast, the facade and northern
northern elevations of the one-story,
frame outbuilding.

APR 3 0 1980

Photo 4 of 5



BRANDON HALL

Adams County, Mississippi

JUN 1 2 1980

Mary W. Miller--1979

From the northwest, the western elevation of the brick outbuilding that has been converted to garage use.

APR 3 0 1980

Photo 5 of 5



BRANDON HALL

Adams County, Mississippi

Mary W. Miller--1979

JUN 12 1980

From the northwest, the western elevation of the brick outbuilding that has been converted to garage use.

Photo 5 of 5

JUL 7 1980



BRANDON HALL

Adams County, Mississippi

Mary W. Miller--1979

JUL 7 1980

From the northeast, the facade and northern elevations of the one-story, frame outbuilding.

JUN 12 1980

Photo 4 of 5